

Think it™

We can build it



Mezzanines



Cantilever Racking



Guardrails



Partitions



Lockers



Accelerated Production



Cogan®
Since 1901



HOW WE WORK

WE'VE BEEN AROUND SINCE 1901 BECAUSE WE TAKE CUSTOMER SATISFACTION VERY SERIOUSLY. WE HANDLE EACH AND EVERY ORDER WITH THE TIME AND ATTENTION IT TAKES TO DO IT RIGHT. THAT EXTRA 'TLC' MEANS YOU'LL ALWAYS GET A SUPERIOR QUALITY PRODUCT THAT FITS YOUR EXACT NEEDS.

Step 1: RFQ/Estimation

The first step in working with Cogan is to submit a full description of your project requirements as well as a layout. Within 24 to 48 hours, you'll receive a detailed estimate complete with preliminary approval plans.

Step 2: Placing an Order

Once your quote has been verified, simply send us your purchase order referencing the applicable Cogan quote number and dollar value. You'll receive an order confirmation from our Credit Department within 24-48 hours (this time includes order entry and credit approval).

Step 3: Engineering & Approval Drawings

No matter the size or dollar value, every custom project we receive gets an approval drawing (except QuickShip orders). It's just responsible manufacturing and we want your order to be perfect.

Feel free to give our Engineering Department a call and leave a detailed voicemail at any time. Any questions or requests will be addressed within 24-48 hours.

Step 4: Production

Once you've signed your approval drawing, your order is scheduled for production. You'll receive an automated shipping window within 48 hours. Production time varies based on the dollar value and complexity of your order.

For current lead times, please visit our website, www.cogan.com/Our-Expertise/How-We-Work.

Step 5: Shipping

We have years of experience shipping orders all over the world and have a number of tools at our disposal to accommodate your needs. We work closely with international transport brokers to get you the best possible freight rate right from the quoting stage. We can ship your order by:

- LTL Standard (most economical, specific delivery time cannot be requested)
- LTL Time Keeper (guaranteed delivery for time-sensitive LTL shipments, available at an additional charge)
- Dedicated Truck (full closed trailer or flatbed, specific delivery time can be requested)
- Train (longer transit times may apply)
- Boat (customer will make arrangements with their own ocean freight forwarder, but Cogan will load the containers)

If you prefer to make your own shipping arrangements, we will provide the total weight, estimated skid dimensions, and any other information you might need to source your own transport. All you have to do is make a pick up appointment with our Transport Department..

Step 6: Material Reception & Staging

Every order that leaves our facility is carefully photographed before and after it has been loaded onto the truck. Shipping photos are sent before your material arrives. You'll know exactly what to expect so you can equip to unload and prepare a staging area.

(In order to avoid any scheduling conflicts, please book your installation team only after the material has been unloaded and staged.)



Photo: Cogan's 100,000+ sqft. state-of-the-art manufacturing facility.

NATIONWIDE SUPPORT

WITH SERVICE SUPPORT ACROSS NORTH AMERICA AND A SUPERIOR PRE-ENGINEERED SYSTEM, NOTHING INSTALLS FASTER THAN THE COGAN LINE OF PRODUCTS.

- | | |
|------------------------|-------------------|
| 1 Montreal, QC | 8 Bluffton, SC |
| 2 Toronto, ON | 9 Plainfield, IL |
| 3 Haverhill, MA | 10 Thornton, CO |
| 4 Livingston, NJ | 11 Seattle, WA |
| 5 Pittsburgh, PA | 12 Riverside, CA |
| 6 Waterford, MI | 13 Tulsa, OK |
| 7 New Philadelphia, OH | 14 Nuevo Leon, MX |



Step 7: Installation & Support

The Cogan pre-engineered system is designed for ease of installation, accuracy and superior quality. We draw from millions of dollars' worth of raw material and work-in-process inventory to manufacture your order exactly how you want it. This standardized system allows for precision results and fast installation.

Our network of reps and independent installers have years of experience working with Cogan products. Installations are completed quickly and accurately with minimal interruption to your workflow. If your project is anywhere in North America, we can have a professional team on your job site in no time.

CUSTOMER CARE

If you require assistance at any point after your order has been placed, our responsive Customer Care Team is at your service. Contact them any time.

E-mail: customer.care@cogan.com



QuickShip

IN STOCK, READY TO SHIP
OR ACCELERATED DELIVERY

We're ready when you are. When you see our QuickShip logo, the product is either kept in stock and ready to ship or available at an accelerated delivery rate.

LIFETIME STRUCTURAL WARRANTY

Over 100 years of experience goes into every product Cogan makes, so when we guarantee the structural integrity of our products for life, it really means something. We've been here since 1901 and we're here to stay.



For complete warranty details, visit our website www.cogan.com.



Mezzanines

Increase Floor Space

MEZZANINE
EXPERTS

Think it
We can build it

AT COGAN, WE ARE THE MEZZANINE EXPERTS. WITH OVER 100 YEARS OF MANUFACTURING EXPERIENCE, THERE'S NO PROJECT WE HAVEN'T SEEN.

Whether you need additional space in your warehouse, parts department, office, or retail store, there is always a good reason to install a Cogan mezzanine. Faster than you ever imagined possible, we can build an industrial strength mezzanine around the existing layout of your facility, matching its exact height, area and load requirements.



Photo: In-Plant Office Mezzanine



Photo: Online Distribution Center Mezzanine



Photo: Conveyor Support Mezzanine

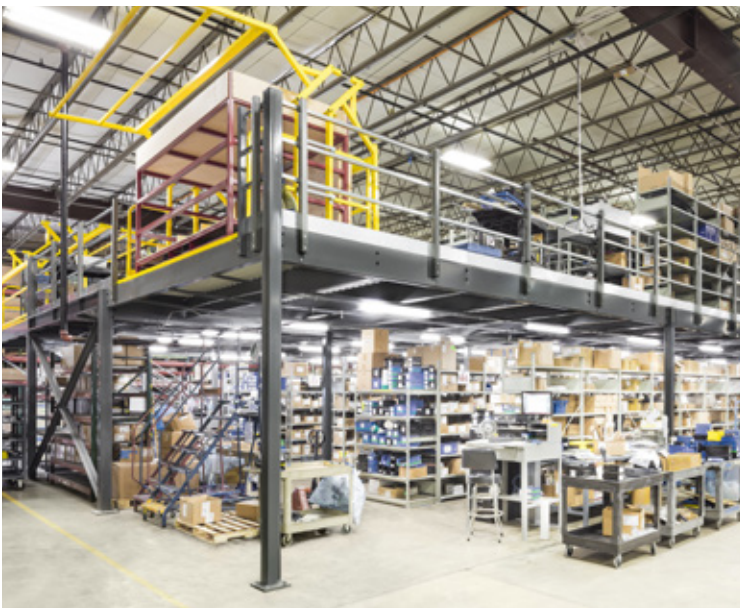

Photo: Parts Inventory Mezzanine



Photo: Warehouse Storage Mezzanine



Photo: Machine Guard Mezzanine with Partition Integration

WHERE YOU SEE CLUTTER,
WE SEE POSSIBILITIES.

PUT OUR EXPERTS TO THE
TEST. WE'RE READY FOR IT.
NO MEZZANINE PROJECT
IS TOO BIG, TOO SMALL, OR
TOO COMPLEX.



Photo: Fitness Center Mezzanine



Photo: Theatre Costume & Prop Storage Mezzanine



Photo: Restaurant & Bar Mezzanine



Photo: Exhibition Platform Mezzanine

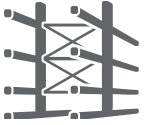

Photo: Sports Facility Mezzanine

QUALITY, STRENGTH AND EFFICIENCY TO KEEP YOUR PROCESS RUNNING SMOOTHLY. REVOLUTIONIZE YOUR WORKSPACE WITH A CUSTOM-BUILT MEZZANINE.



Photo: Kids' "Fun Zone" Mezzanine



Cantilever Racking

Store Any Size, Any Shape

Think it
We can build it

IDEAL FOR STORING SHORT, LONG OR AWKWARDLY-SHAPED ITEMS, COGAN CANTILEVER RACKING OPTIMIZES THE PRODUCTIVITY AND PROFITABILITY OF YOUR WORK ENVIRONMENT.



Photo: Cantilever Racking for Metal Tube & Piping Storage

Designed for outstanding strength and durability, our cantilever racking features a special arm system that allows for easy front loading without obstruction. From tubing and piping to plywood, dry wall, steel sheets and lumber, Cogan cantilever racking is the perfect system for oversized storage.

Structural steel components guarantee superior strength. Punched holes run the full height of each column for excellent adaptability and adjustability. Built for the toughest industrial applications, all connections use high-strength structural grade bolts.

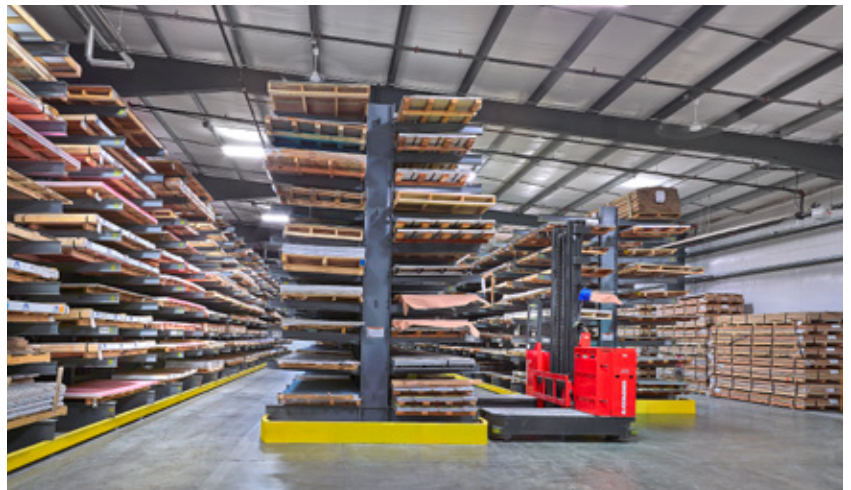

Photo: Very Narrow Aisle (VNA) Cantilever Racking



Photo: Lumberyard Cantilever Racking



Photo: Outdoor Cantilever Racking

REFLECTING OUR DEDICATION TO INDUSTRY LEADERSHIP, COGAN CANTILEVER RACKING IS ANOTHER PRIME EXAMPLE OF HOW WE BRING VISION, STRENGTH AND INNOVATION TO THE WORKPLACE.



Photo: Cantilever Outdoor Storage Sheds



Photo: Four Season Cantilever Roofs



Guardrails

A Safe Workplace

Think it
We can build it

TRUBLE-FREE FOR YOUR PEACE OF MIND. PROTECT YOUR PEOPLE AND YOUR PROPERTY FROM THE GROUND UP WITH COGAN GUARDRAILS, SAFETY RAILS AND RACK PROTECTORS.

Use Cogan guardrails to safeguard conveyor systems, manufacturing equipment, electrical panels, computer stations, staircases and walkways, in-plant offices, first aid and restroom areas, rack posts and rack-aisle-ends, or anywhere else crash protection is required. The all-steel construction works around the clock to keep your workplace safe, productive and profitable. All guardrail solutions feature simple nut-and-bolt connections for easy and fast assembly. You benefit from a safer work environment that protects your people, products and profits - securely and reliably.



Photo: Rack-Aisle-End Rack Protectors



Photo: Electrical Panel Protection Double Rail Guardrail



Photo: Equipment Protection Single Rail Guardrail

SAFETY 24/7. INSTALL A GUARDRAIL SYSTEM AND CREATE A PROTECTIVE SHIELD BETWEEN YOUR WORKERS AND YOUR EQUIPMENT.



Photo: Traffic Control Pedestrian Barriers



Photo: Loading Dock Protection Bollards



Photo: Rack Post Protection Guards



Partitions

24/7 Security

Think it
We can build it

ON THE JOB 24/7. CREATE SECURE, RELIABLE AND FUNCTIONAL WORK OR STORAGE SPACE EXACTLY WHERE YOU NEED IT WITH A COGAN PARTITION SYSTEM.

Safety, security and protection are just a few things that come standard with a Cogan partition system. The all-steel construction resists wear and requires no maintenance, saving you valuable time and money. Whether you choose from our standard options or prefer a custom configuration, our experienced staff will make sure you get what's best for you.



Photo: Sheet Metal & Lexan Workspace Division Partition



Photo: Archival Document Security Partition



Photo: Sheet Metal Weldina Cell Partition



Photo: Robot & Conveyor Machine Guarding Partition



Photo: DEA Drug Storage Cage

DEVELOPED BY COGAN OVER 50 YEARS AGO, OUR PARTITIONS HAVE STOOD THE TEST OF TIME AND CONTINUE THE TRADITION OF QUALITY, FUNCTIONAL DESIGN AND STRUCTURAL INTEGRITY THAT HAS MADE US AN INDUSTRY LEADER.



Photo: Back-of-Rack Protection Guards



Lockers

Lock-It-Up

Think it
We can build it

FROM TENANT AND WAREHOUSE STORAGE TO EMPLOYEE, DORMITORY, MILITARY AND EQUIPMENT STORAGE, COGAN HAS THE PERFECT LOCKER SYSTEM TO FIT YOUR NEEDS, YOUR APPLICATION AND YOUR BUDGET.

The open wire mesh a design ensures your property remains in constant view while allowing air to circulate and light to penetrate fully. With fewer components, installation is fast and easy. Lockers can be assembled using basic hand tools, eliminating the need for skilled labour. Durable powder-coated or electro-galvanized finish is wear-resistant and maintenance-free. Your system looks great even after years of use.



Photo: Freestanding Tenant Storage Lockers

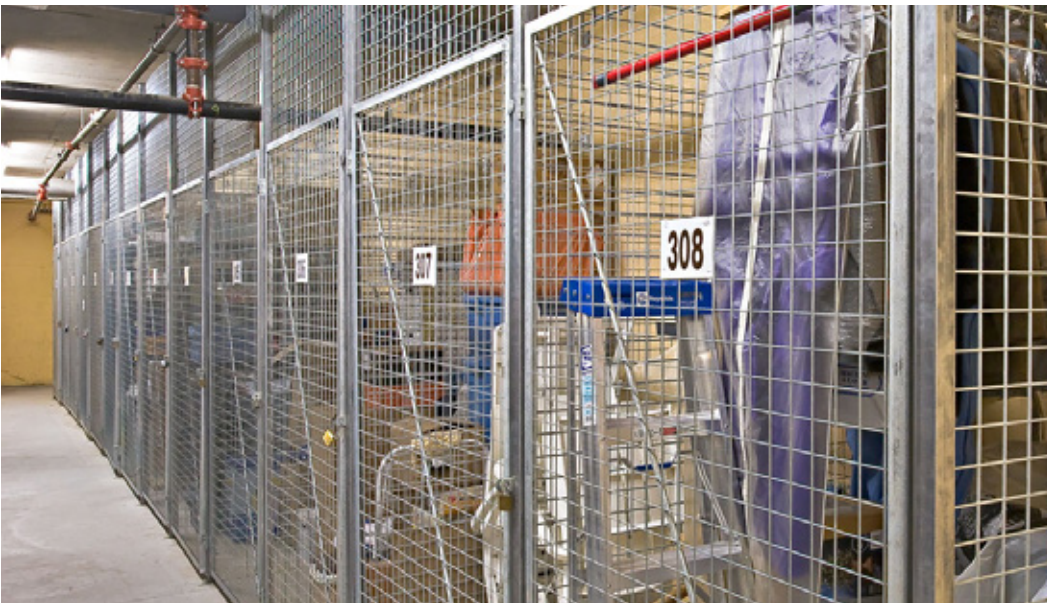

Photo: Floor-to-Ceiling Tenant Storage Lockers



Photo: Parking Garage Hanging Lockers



Photo: Double Tier University Storage Lockers



Photo: TA-50 Gear Lockers



Photo: Bulk Storage Lockers

INFINITELY ADAPTABLE FOR EVERY DAY USE, COGAN LOCKERS ARE THE DURABLE, PRACTICAL AND MULTI-PURPOSE SOLUTION FOR CONVERTING ANY SPACE INTO A SECURE STORAGE AREA.



Accelerated Production

2-Week Delivery on Select Items

Need it fast? Accelerated Production orders are assembled from raw components that we keep in stock. This allows us to fast-track your order through our abbreviated production process.



Accelerated Production
2-Week Delivery on Select Items

HEAVY-DUTY GUARDRAILS

Item Description

A. Rails

- 2' Rail (19" exact length)
- 3' Rail (31" exact length)
- 4' Rail (43" exact length)
- 5' Rail (55" exact length)
- 6' Rail (67" exact length)
- 7' Rail (79" exact length)
- 8' Rail (91" exact length)
- 9' Rail (103" exact length)
- 10' Rail (115" exact length)

B. Columns & Accessories

- Double Rail Column (centered baseplate)
- Double Rail Column (offset baseplate)
- Single Rail Column (centered baseplate)
- Single Rail Column (offset baseplate)
- Lift-Out Brackets (pair)
- 5/8" x 4 1/2" Floor Anchors (4x/pkg)

Item

- QS-GR2
- QS-GR3
- QS-GR4
- QS-GR5
- QS-GR6
- QS-GR7
- QS-GR8
- QS-GR9
- QS-GR10

- QS-GPDC
- QS-GPDO
- QS-GPSC
- QS-GPSO
- QS-GL1
- QS-GFA5

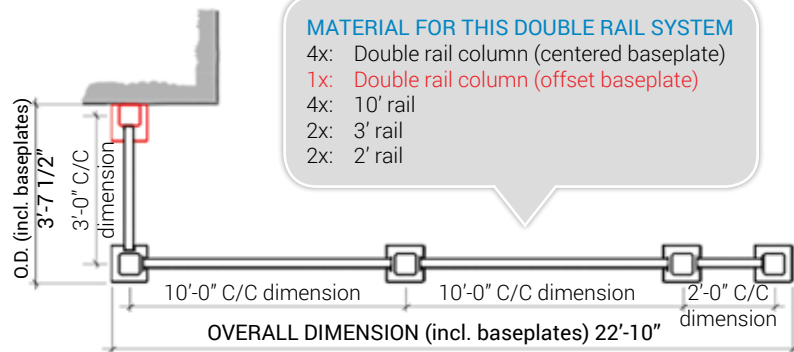

MATERIAL FOR THIS DOUBLE RAIL SYSTEM

- 4x: Double rail column (centered baseplate)
- 1x: Double rail column (offset baseplate)
- 4x: 10' rail
- 2x: 3' rail
- 2x: 2' rail

SPECIFICATIONS

12-gauge steel / unassembled components

Absorbs impact of a 10,000 lb load at 4 mph. 12-gauge roll-formed steel, 12" high profile, 3/16" thick end plates punched with two $\varnothing 9/16$ " connection holes. 5" x 5" seam welded square columns welded to a 10" x 10" x 1/2" baseplate with $\varnothing 3/4$ " mounting holes. Black plastic post caps. Install with floor anchors (sold separately).

Double Rail Column



Single Rail Column

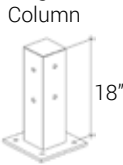

Centered Baseplate



Offset Baseplate



Lift-out Bracket



Rail



FINISH

Powder-coated safety yellow



Bollards

SPECIFICATIONS

1/8" thick steel tube
4 1/2" or 6" diameter
Sturdy welded baseplate is made of 1/2" thick steel plate. Includes $\varnothing 3/4$ " bolt holes for floor anchors (sold separately). Black plastic top cap.

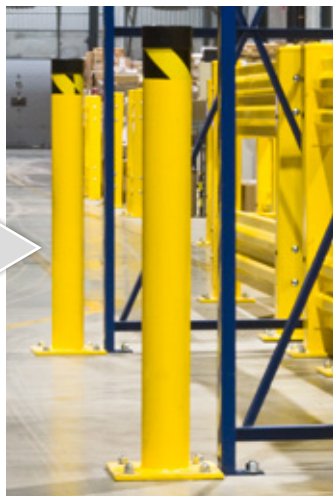

Item Description

- 42" High Bollard (4 1/2" dia. + 10" x 10" baseplate)
- 5/8" x 4 1/2" Floor Anchors (4x/pkg)

FINISH

Powder-coated safety yellow



Item

- QS-B42
- QS-GFA1

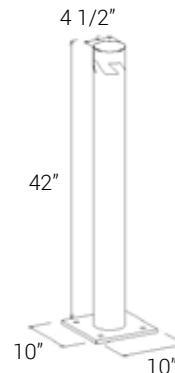



Accelerated Production
2-Week Delivery on Select Items

WIRED MESH RACK GUARDS

SPECIFICATIONS

All-welded angle frame
2" x 2" x 10GA welded wire mesh
Offset mounting brackets
Form a sturdy wall of protection between your workers and your inventory. Rigid and resilient, rack guards bolt directly to racking uprights, placing a barrier between stored materials and picking aisles below.

FINISH

Powder-coated
Cogan grey



Bracket



6" offset

Plan View of Racking



94" panel for 96" rack beam
142" panel for 144" rack beam

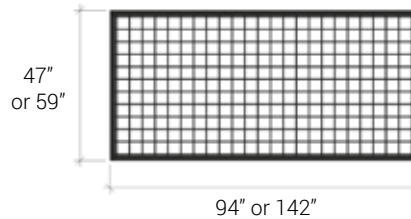

Item Description

A. Rack Guard Panels

Item Description	Item #
8'W x 4'H	QS-W84
8'W x 5'H	QS-W85
12'W x 4'H	QS-W124
12'W x 5'H	QS-W125

B. Brackets (sold separately)

8" Bracket (for 6" offset)	QS-CMBS06
----------------------------	-----------

* 4 brackets are required per panel.

Rack Aisle Protectors

SPECIFICATIONS

Fits any upright width
Curved crescents fit around rack corners to protect from impact damage. 12"H x 3/8" steel crescent plate welded to 3" x 5" x 1/4" steel angle. $\varnothing 3/4$ " bolt holes accept floor anchors (sold separately). Available in single- or double-sided wrap around.



FINISH

Powder-coated
safety yellow



Item Description

Item Description	Item #
42" Left Rack Aisle Protector	QS-RP42L
42" Right Rack Aisle Protector	QS-RP42R
48" Left Rack Aisle Protector	QS-RP48L
48" Right Rack Aisle Protector	QS-RP48R
48" Double-Sided Rack Aisle Protector	QS-RPD48
5/8" x 4 1/2" Floor Anchors (3x/pkg)	QS-GFA3

Single-Sided Wrap Around

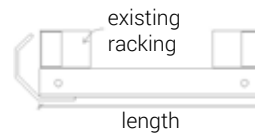

Double-Sided Wrap Around

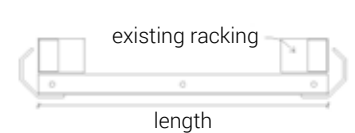

Rack Post Protectors

SPECIFICATIONS

3/16" thick steel
Fits up to a 5"W upright
8 1/4"W x 6"D baseplate
 $\varnothing 5/8$ " bolt holes. Floor anchors sold separately. Easy installation.



Item Description

12"H Rack Post Protector	QS-RP12
18"H Rack Post Protector	QS-RP18
24"H Rack Post Protector	QS-RP24
1/2" x 4 1/4" Floor Anchors (4x/pkg)	QS-GFA4

FINISH

Powder-coated
safety yellow



Item

QS-RP12
QS-RP18
QS-RP24
QS-GFA4

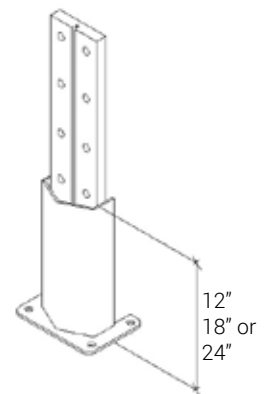
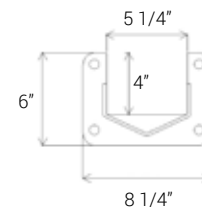

Floor Angle Guide

SPECIFICATIONS

5" x 3" x 1/4" structural steel

Provides continuous, uninterrupted protection low to the ground. Acts as a barrier to prevent narrow-aisle fork trucks, lifts and order pickers from damaging storage racks.

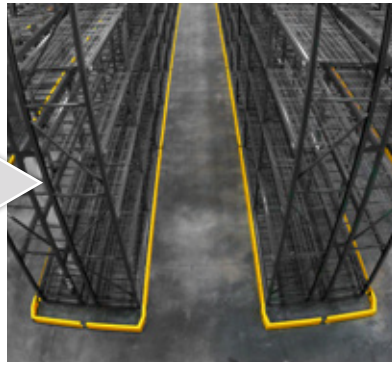

Item Description

- 48" L Floor Angle Guide
- 96" L Floor Angle Guide
- 5/8" x 4 1/2" Floor Anchors

Item

- QS-RPFAG48
- QS-RPFAG96
- QS-GFA8



* Anchor holes are equally spaced.

FINISH

Powder-coated safety yellow



Self-Closing Safety Gates

SPECIFICATIONS

Adjustable length 22" to 36" or 33" to 48"

Exclusive Universal Mounting Adapter

Spring-loaded hinges for 90° reversible rotation

Spring-loaded hinges allow the gate to close automatically, reducing the risk of accidentally walking or backing into the opening. The flexibility of the spring allows the gate to swing back and forth, making both sides easily accessible. Compatible with heavy-duty guardrail, pedestrian rail and mezzanine systems.

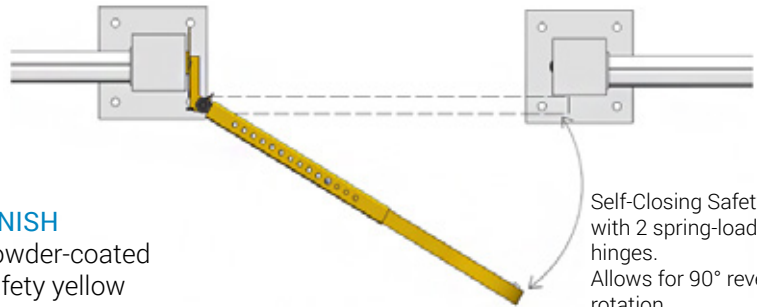

FINISH

Powder-coated safety yellow



Self-Closing Safety Gate with 2 spring-loaded hinges. Allows for 90° reversible rotation.

Plan View

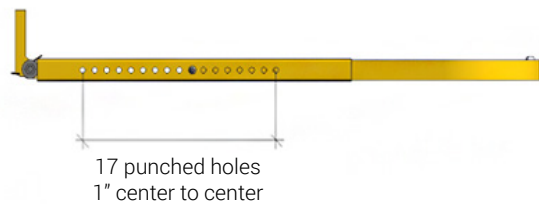
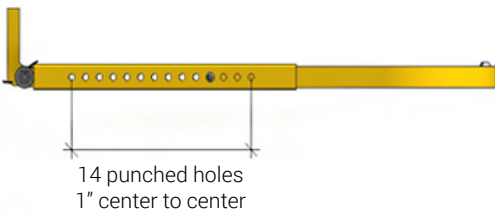

Overall Length

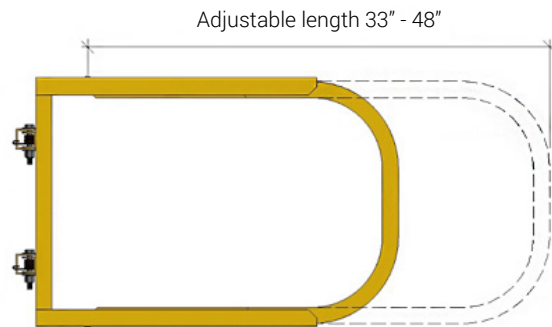
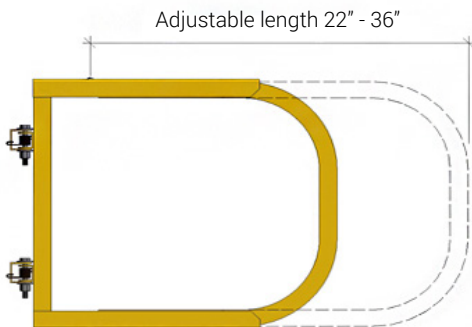

ORIGINAL WIRE MESH PARTITIONS



SPECIFICATIONS

2" x 2" x 10GA welded wire mesh panels framed in 1 1/4" x 1/4" x 12GA structural angle with $\phi 1/2"$ reinforcement rods. 2" x 2" seam welded square tube posts welded to 6" x 6" baseplate / 4" sweep

Create secure and reliable work or storage space exactly where you need it. All-steel construction is wear-resistant and maintenance-free. Open wire mesh design allows air to circulate and light to penetrate fully. Modular nut-and-bolt assembly. Floor anchors sold separately. .

FINISH

Powder-coated Cogan grey



Item Description

Item

A. Panels

Standard Panel 2'W x 4'H (exact size 22"W x 47"H)	QS-P024
Standard Panel 3'W x 4'H (exact size 34"W x 47"H)	QS-P034
Standard Panel 4'W x 4'H (exact size 46"W x 47"H)	QS-P044
Standard Panel 5'W x 4'H (exact size 58"W x 47"H)	QS-P054
Standard Panel 6'W x 4'H (exact size 70"W x 47"H)	QS-P064
Standard Panel 8'W x 4'H (exact size 94"W x 47"H)	QS-P084
Standard Panel 10'W x 4'H (exact size 118"W x 47"H)	QS-P104
Adjustable Flex Panel (2' to 12' x 8'H)	QS-PFP1

B. Posts (8' high)

Original Partition Line Post	QS-PPL08
Original Partition Corner Post	QS-PPC08
Original Partion Wall/Door Post	QS-PPW08
Wall Bracket	QS-P-PWB
Floor Anchors 3/8" x 2 3/4" (4x/pkg)	QS-FAEF11

Layout Example (Plan View)

Framed 2" x 2" x 10GA welded wire mesh



Std. panels are stacked to create 8'H sections:
(1) 10' x 8' panel section =
(2) 10' x 4' standard panels

MATERIAL FOR STANDARD 2-WALL PARTITION SYSTEM

- 2x: Standard panel 8' x 4'
- 2x: Standard panel 10' x 4'
- 2x: Standard panel 4' x 4'
- 1x: Single swing gate 3' x 8'
- 2x: Standard panel 5' x 4'
- 1x: Adjustable flex panel
- 2x: Line post 8'
- 1x: Corner post 8'
- 3x: Wall/Door post 8'

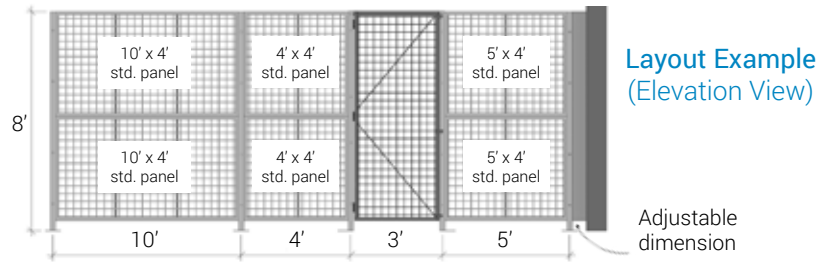
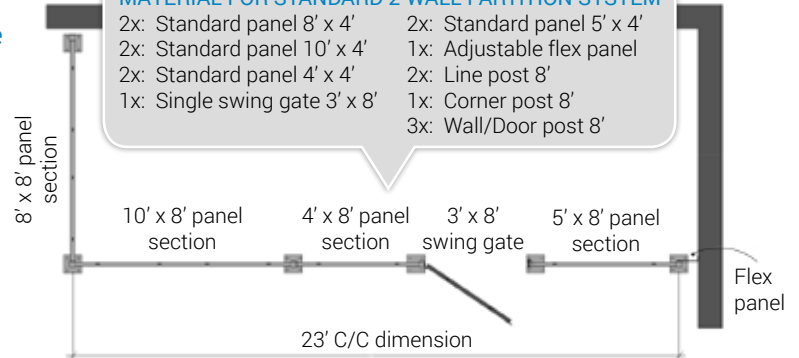

Gates

SPECIFICATIONS

Made of 2" x 2" x 10GA welded wire mesh framed in 1 1/4" x 1 1/4" x 12GA structural angle with two welded $\phi 1/2"$ reinforcement rods. Padlock hasp and hinges included. **Track is included for sliding doors.**

Single Swing Gate

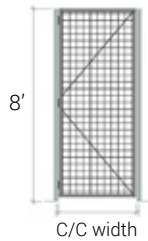

Sliding Gate

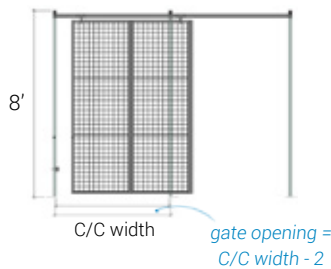

Padlock Hasp



Standard padlock hasp (padlock by others). No charge. Included with all doors.

Item Description

Item

A. Single Swing Gates (C/C width)

Single Hinge Gate 3'W x 8'H	QS-P-D-SH-3x8
-----------------------------	---------------

B. Sliding Gates (C/C width)

Single Slide Gate 4'W x 8'H	QS-P-D-SS-4x8
Single Slide Gate 8'W x 8'H	QS-P-D-SS-8x8

Standard Colors

Standard colors are applied to all products and are automatically included in the material price on your quote. Unless otherwise specified, all standard colors are powder-coated for a durable, long-lasting and maintenance-free paint finish.

Mezzanines
Partitions
Lockers
Cantilever Racking



Cogan Grey

Machine Guarding



Midnight Black



Safety Yellow

Guardrails



Safety Yellow



Cogan[®]
Since 1901

Cogan Wire & Metal Products Ltd.

Phone (800) 567.2642

Fax (800) 633.3004

info@cogan.com

www.cogan.com

