

STANDARD

RACKPOST PROTECTOR SPECIFICATIONS:

- RACKPOST PROTECTOR CRESCENT MADE OF FORMED METAL $\frac{3}{8}$ "
- RACKPOST BASEPLATE 8"x4"x $\frac{1}{4}$ ".

FIELD MEASUREMENTS

ALL FIELD MEASUREMENTS MUST BE VERIFIED AND GIVEN TO COGAN, IN OPENING SIZE WITH NO REDUCTIONS. COGAN WILL REDUCE ALL OPENINGS ACCORDING TO THEIR NEED FOR DOOR AND PANEL CLEARANCE REQUIREMENTS.

LEGEND:

- ARL: ACTUAL RAIL LENGTH
- C/C: CENTER TO CENTER
- O.D.: OUTSIDE DIMENSION
- THE COMPONENTS ARE COLORED WITH ONE COAT OF COGAN POWDER YELLOW PAINT.

CHECK & RETURN PROMPTLY * JOB SHIP DATE SET AFTER RECEIPT OF FINAL APPROVAL *

DIMENSIONS & DESIGN SHOWN

- APPROVED (NO CHANGES)
- APPROVED WITH CHANGES
- REVISE & RESUBMIT
- NOT APPROVED

SIGN: _____

PRINT NAME: _____

BY APPROVING THESE DRAWINGS, THE CLIENT AND/OR OWNER ARE ACCEPTING THAT THESE DESIGNS MAY BE OR ARE AN ALTERNATIVE TO THE SPECS AND/OR DESIGNS PREVIOUSLY PROVIDED TO COGAN.



PROJECT NAME: _____

CLIENT NAME: _____ DRAWING #: _____

DATE: _____ DRAWN BY: _____ VERIFIED BY: _____ REVISION: _____

SCALE: NTS	DATE: ***	DRAWN BY: ***	VERIFIED BY: ***	REVISION: X	PAGE: 1/1
------------	-----------	---------------	------------------	-------------	-----------

IMPORTANT NOTE

THE CLIENT AND/OR OWNER SHALL BE RESPONSIBLE FOR ALL QUANTITIES AND DIMENSIONS INCLUDING THE VERIFICATION OF, AND COORDINATION WITH FIELD CONDITIONS. THE CLIENT AND/OR OWNER SHALL VERIFY ALL CRITICAL DIMENSIONS AND CONDITIONS OF EXISTING CONSTRUCTION THAT RELATE TO THIS PROJECT PRIOR TO MANUFACTURING. COGAN MUST BE NOTIFIED IN WRITING OF ANY ELEMENTS FOUND TO BE INCONSISTENT OR NOT COMPATIBLE WITH THE DETAILS INDICATED BY THESE APPROVAL DRAWINGS.

THE CLIENT AND/OR OWNER MUST SUBMIT SIGNED (APPROVED) DRAWINGS PRIOR TO THE START OF THE PRODUCTION.

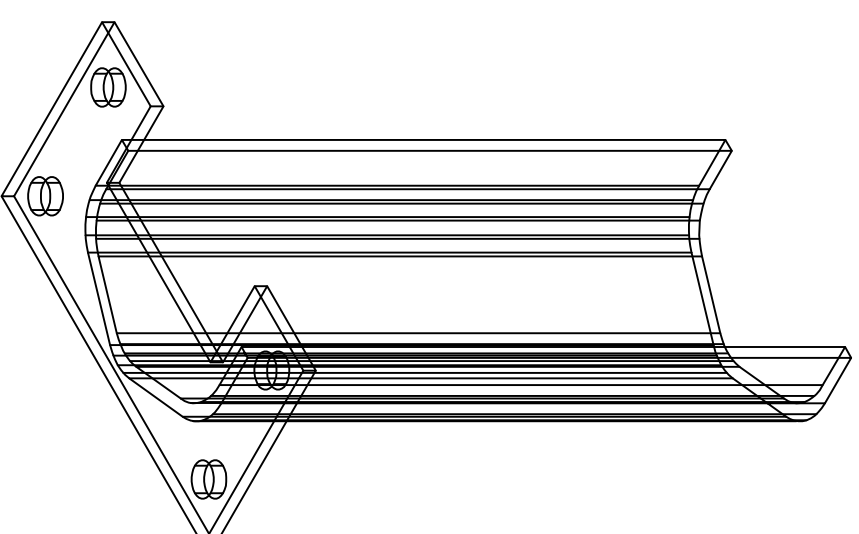
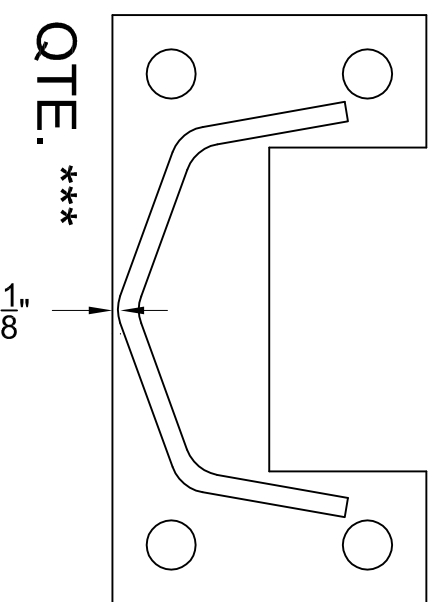

DO NOT MAKE ANY MODIFICATIONS TO CORRECT ANY PROBLEM, BE IT PRODUCT OR SITE CONDITION, WITHOUT FIRST CONTACTING OUR CUSTOMER SUPPORT DEPARTMENT AT COGAN WIRE (1-800-567-2642). DOING SO MAY AFFECT YOUR PRODUCT WARRANTY AND COGAN WILL NOT BE RESPONSIBLE FOR ANY UNAUTHORIZED WORK. CUSTOMER SUPPORT IS AVAILABLE DURING REGULAR BUSINESS HOURS 8AM-5PM, MONDAY-FRIDAY.